

primus

Industrial Tumble Dryer T 9



FEATURES

- Standard stainless steel drum with large diameter
- Easy to use microprocessor
- Combination of Radial and Axial airflow - RADAX® concept:
 - maximal heat transfer
 - low energy consumption
 - short drying time
- Large door opening for easy loading and unloading

OPTIONS

- Coin operated version
- Reversing drum
- Full Control programmer
- Residual moisture control Sensodry®:
 - safe drying of delicate linen
 - humidity detection in °C
 - ideal in combination with SoftWash®
 - ideal for dry cleaners, fire depts
 - available on Easy and Full Control
- LPMS networking software
- Stainless steel front

radax^{airflow}®

senso.dry®

TYPE		T 9
CAPACITY		
Drum capacity	kg	9
Drum volume	l	190
Drum dimensions	mm	ø760x420
Number of drums		1
Number of loading doors		1
AIRFLOW	m ³ /h	minimum 356, optimal 450
DRYING AVERAGE	l/min.	0,150
MOTORS		
Fan	kW	0,37
Drive	kW	0,18
GAS HEATING		
Gas connection	inch	3/4"
Electrical connection		3x380-415V 50/60Hz 3x220-240V 50Hz 3x208-240V 60Hz 3x440V 60Hz 1x208-240V 60Hz 1x220-240V 50/60Hz
Energy	kW	12,5
	kBTU/h	42,7
ELECTRICAL HEATING		
Electrical connection		3x380-415V 50/60Hz 3x220-240V 50Hz 3x208-240V 60Hz 3x440V 60Hz
Energy	kW	6/9/12
PROGRAMMER		
Easy control - antivandal		Standard
Full control		Available
EXHAUST	mm	ø150
DIMENSIONS		
Size HxWxD	mm	1465x795x815
TRANSPORT DATA		
Gross weight	kg	180
Net weight	kg	170
Packed HxWxD	mm	1570x840x835

- | | | |
|---|--|--|
| 1. Programmer | 7. Name plate | 14. Airflow switch |
| 2. Emergency stop button (not applicable for version with coin meter) | 8. Main switch | 15. Suction |
| 3. Lint screen cover | 9. Main power supply | 16. Exhaust piping |
| 4. Door lock microswitch | 10. Heating chamber | 17. Coin meter (version with coin meter) |
| 5. Lint cover microswitch | 11. Gas valve (G models only) | 18. Coin box (version with coin meter) |
| 6. Lint screen | 12. Pressure regulator (G models only) | |
| | 13. Gas supply (G models only) | |

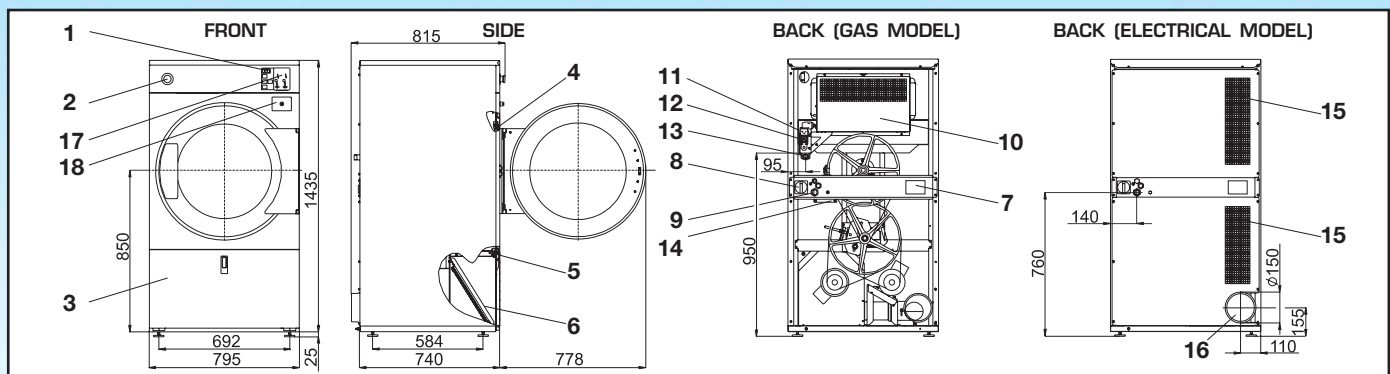

The company Primus bvba preserves the right to change the machines and the specifications in this leaflet at any time, without prior notice. Details and photographs are only for information and never binding.

www.primuslaundry.com

primus

Quality **without**
compromise

Bvba
Certified Company
ISO 9001
ISO 14001

