

primus

Rigid Mounted Industrial Washer Extractor RS 27, RS 35



FEATURES

- Rigid mounted, medium spin
- Stainless steel cabinet (AISI 304)
- Stainless steel drum and tub
- Large drain valves (Ø76 mm on RS 27, 2xØ76 mm on RS35)
- Easy access to all parts
- Patented soap hopper and drain valve (Liqui-Mix® system)
- Standard liquid soap connections
- Frequency controlled motor
- PowerWash perforated lifting ribs: more mechanical action, lower water consumption
- Measurement of unbalance by means of frequency inverter

OPTIONS

- Full control (FC) microprocessor
- Liquid soap pumps
- Coin operated timer
- Anti-vandalism fascia panel
- Water recovery kit
- Trace-Tech® traceability software and networking system

TRACE-TECH®
Liqui-mix®
POWERWASH®

TYPE		RS 27	RS 35
CAPACITY			
Drum volume	l	269	355
Capacity	kg/lb	27/60	35/80
Drum dimensions	mm	Ø750x610	Ø914x505
MOTOR			
Frequency controlled		standard	standard
DRUM SPEED			
Wash speed	rpm	42	38
Spin speed	rpm	490	510
G-factor spin speed		100	130
PROGRAMMER			
Microprocessor EC		standard	standard
Microprocessor FC		+	+
CABINET			
Stainless steel AISI 304		standard	standard
FIXING		yes (6 pcs M20x320)	yes (6 pcs M20x320)
HEATING			
100% hot water	°C	90	90
	°F	194	194
100% electrical	kW	18-24	18-24
Steam high pressure	bar	3-8	3-8
CONNECTION			
Electrical		1x220-240V 50/60Hz, 3x220-240V 50/60Hz 3x380-415V+N 50/60Hz, 3x380-480V 50/60Hz	
Water inlet	inch	3/4"	
Steam inlet	inch	3/4"	
DIMENSIONS			
HxWxD	mm	1380x870x1140	1460x1100x1140
TRANSPORT DATA			
Gross weight			
Case packing	kg	470	740
Net weight	kg	410	710
Volume (packed)			
Case packing	m ³	1,82	2,25
Case packing HxWxD	mm	1570x950x1220	1630x1150x1200
+ = Available Standard = Standard version			

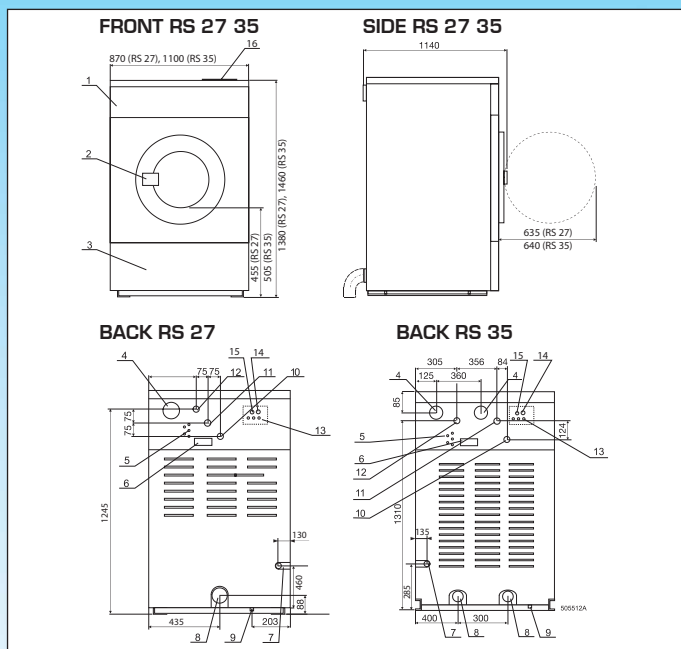

1. Control panel
2. Door handle
3. Service panel
4. Air vent
5. Liquid soap hose connections
6. Name plate
7. Steam connection
8. Drain connection
9. Earthing connection
10. Hot water connection
11. Cold soft water connection
12. Cold hard water connection
13. Fuses
14. Electrical connection of machine
15. Electrical connection to liquid soap pumps
16. Soap hoppers

The company Primus preserves the right to change the machines and the specification in this leaflet at any time, without prior notice. Details and photographs are only for information and never binding.

www.primuslaundry.com

primus

Quality **without**
compromise

BVQI
Certified Company
ISO 9001
ISO 14001

