

# primus

## Industrial Cylinder Heated Drying Ironers with Rear Return IR 50 and Length Folding IF 50



### FEATURES

- Large surface contact with linen over an angle of 300°
- Chrome-plated cylinder for a better thermal conduction
- Finger protection and emergency button for more safety
- Durable NOMEX ironing belts
- Automatic cooldown
- Easy to operate microprocessor: 20 pre-set ironing programmes
- Indication of ironing speed and temperature
- Reverse mode possible
- Variable setups for folding
- IF model: integrated length folder model
- IR model: front and rear return
- Frequency-controlled motors
- Easy to remove lint filters
- Standard anti-static bar
- Easyfold® system requires less maintenance (no ribbons and rolls)
- Electric, gas or steam heating

### OPTIONS

- Foot pedal for easy start and stop operation

**EASYFOLD®**

TYPE		IF/IR 50-200	IF/IR 50-250	IF/IR 50-320
<b>ROLLER DIAMETER</b>	mm	500	500	500
<b>USEFUL ROLLER LENGTH</b>	mm	2000	2500	3200
<b>HEATING</b>				
Electric heating	kW	38	55	65
Gas heating	kW	36	52	66
Steam heating	kg/h	49	68	88
<b>MOTOR</b>				
Roller motor	kW	0,37	0,37	0,37
Fan motor	kW	0,18/0,255	2x0,18/0,255	2x0,18/0,255
<b>CAPACITY*</b>	kg/h	50	70	90
<b>ROLLER SPEED</b>	m/min.	1,5-8	1,5-8	1,5-8
<b>ELECTRIC CONNECTION</b>		3+PE+N 380-415V 50/60Hz 3+PE 208-240V 50/ 60Hz		
<b>DIMENSIONS</b>				
HxWxD	mm	1568x2750x1185	1568x3350x1185	1568x3950x1185
<b>TRANSPORT DATA</b>				
Gross weight (Crate packing)	kg	1520	1700	2000
Net weight	kg	1290	1440	1680
Volume (packed)				
Crate packing	m <sup>3</sup>	7,67	9,2	10,76
Crate packing HxWxD	mm	1900x2976x1356	1900x3576x1356	1900x4176x1356

\* The mentioned capacities are only indicated values while the capacity is dependent on the residual moisture, the kind of linen, ironing temperature, pressure of the ironing bed, condition of the surface and the skill of the operators (idem for consumption)

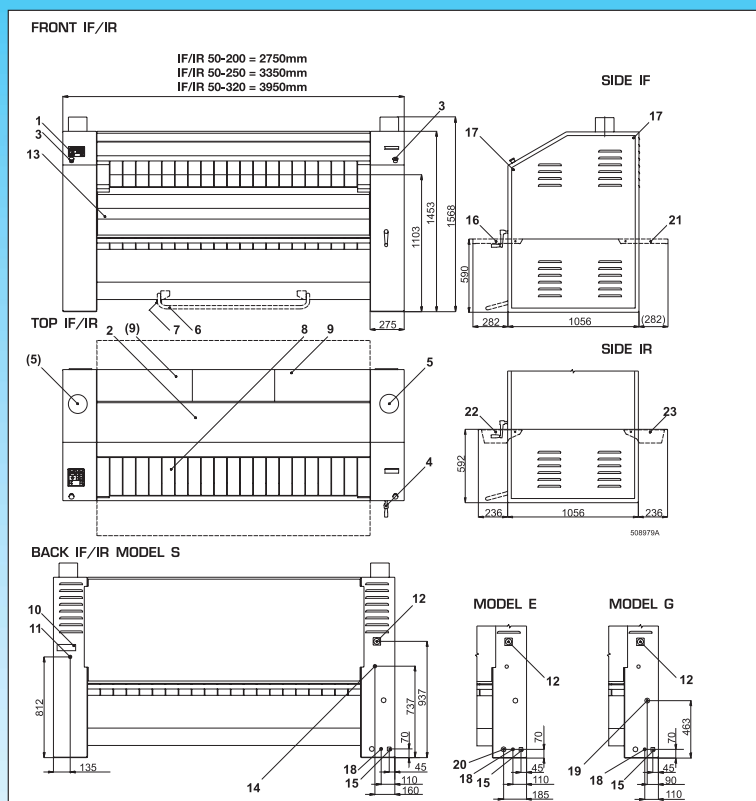

1. Control panel
2. Upper cover
3. Centralstop
4. Manual drive of roller
5. Exhaust ventilation
6. Pedal used for starting/stopping belts movement (according to order; only for version OPL)
7. Pedal microswitch (according to order; only for version OPL)
8. Feeding belts/feeding table
9. Cover of filter sieve
10. Name plate
11. Condense drain G3/4" (only for version "S")
12. Main switch
13. Upper trough
14. Steam supply G3/4" (only for version "S")
15. External protective connector
16. Output tilting table - front
17. Bolts of side cover
18. Main supply of electric power
19. Gas supply G3/4" (only for version "G")
20. Power supply for heating system (only for version "E")
21. Output tilting table - rear (according to order)
22. Output tilting trough - front
23. Output tilting trough - rear

The company Primus bvba preserves the right to change the machines and the specification in this leaflet at any time, without prior notice. Details and photographs are only for information and never binding.

[www.primuslaundry.com](http://www.primuslaundry.com)

primus

Quality without compromise

